



# Sedgwick County Fire District 1

Administrative Office: 7750 N. Wild West Dr. - Park City, KS 67147  
Phone: 316-660-3473 - [www.sedgwickcounty.org](http://www.sedgwickcounty.org) - Fax: 316-660-3474



*Sedgwick County...  
working for you*

## Application for Service Drive Requirements for Structures

The Sedgwick County Code requires that a service drive be provided when any part of a structure, which is being built, or being moved on to the property, is more than 200 feet from the edge of an approved road or street. A permit must be applied for when building permits are obtained to build a structure or to move a structure on to a site. A legible site plan must be submitted an application time with access drive dimensions and distance from roadway to back of structure. Non-legible site plans will be rejected.

The Service Drive shall be completed, inspected, and approved by Sedgwick County Fire District 1, prior to or at the time of the framing inspection. An application fee of \$75.00 will need to be submitted before any inspections will occur.

Any project not constructed with a Service Drive meeting the requirements of this code shall not be granted a framing inspection and/or Certificate of Occupancy of any type and the permit applicant will be subject to enforcement proceedings as provided in this Article and/or additional legal proceedings.

To schedule an inspection you must contact Sedgwick County Fire District 1, if called prior to 9:00 am inspection can be scheduled for that day, if after 9:00 am inspection will be conducted on the next working day. They can be contacted at 660-3473.

The basic design requirements are:

1. The driving surface is to be no less than 20 feet wide
  - a. Designed to withstand the weight of fire apparatus (46,000 lbs.) in inclement/wet weather.
  - b. The surface is to be an all-weather material consisting of rock or gravel, ground asphalt, laid asphalt or concrete and shall be compacted to provide a solid base.
  - c. is to be applied a minimum of 4 inches in depth consistently over the entire driving surface (sand does not provide a good base but may be used as a topping or smoothing finish to the drive)
2. Vertical clearance no less than 13 feet 6 inches the entire length of the driving surface is required.
3. An approved turn-around must be provided that allows the turning of apparatus in no more than two maneuvers (see illustrations for examples)
4. Any gates, entryways, poles, barriers or other obstructions located on a service drive shall be set back from the County, Township, or other approved road a minimum of thirty feet.
5. All distances stated as 200 feet or more as used in the code shall be measured using the most direct route of travel by ground, not "as the crow flies".
6. If a bridge is required for access, it is to be constructed and maintained to carry the imposed loads of fire apparatus. The bridge is to be structurally calculated by an engineer and documentation provided to the Department of Code Enforcement with the access drive permit application.
7. If the access drive goes through any portion of land designated in a flood plain the installation of culverts, bridges or similar crossings are to be approved by the flood plain manager. The drive must be elevated to a point that is at least twelve inches above the flood plain.

**SEDGWICK COUNTY FIRE DEPARTMENT  
FIRE DEPARTMENT ACCESS DRIVE SITE PLAN**

**DATE OF APPLICATION:** \_\_\_\_/\_\_\_\_/\_\_\_\_

**BUILDING PERMIT No:**

---

**PROPERTY ADDRESS:**

---

**PROPERTY OWNER/S NAME and E-MAIL ADDRESS:**

---

The property site plan is shown below which is not to scale. It does include distances to all buildings on the site, dimensions of access drive and turn-around, and building set back distances. The plan does have a "NORTH" arrow.

Site Plan:

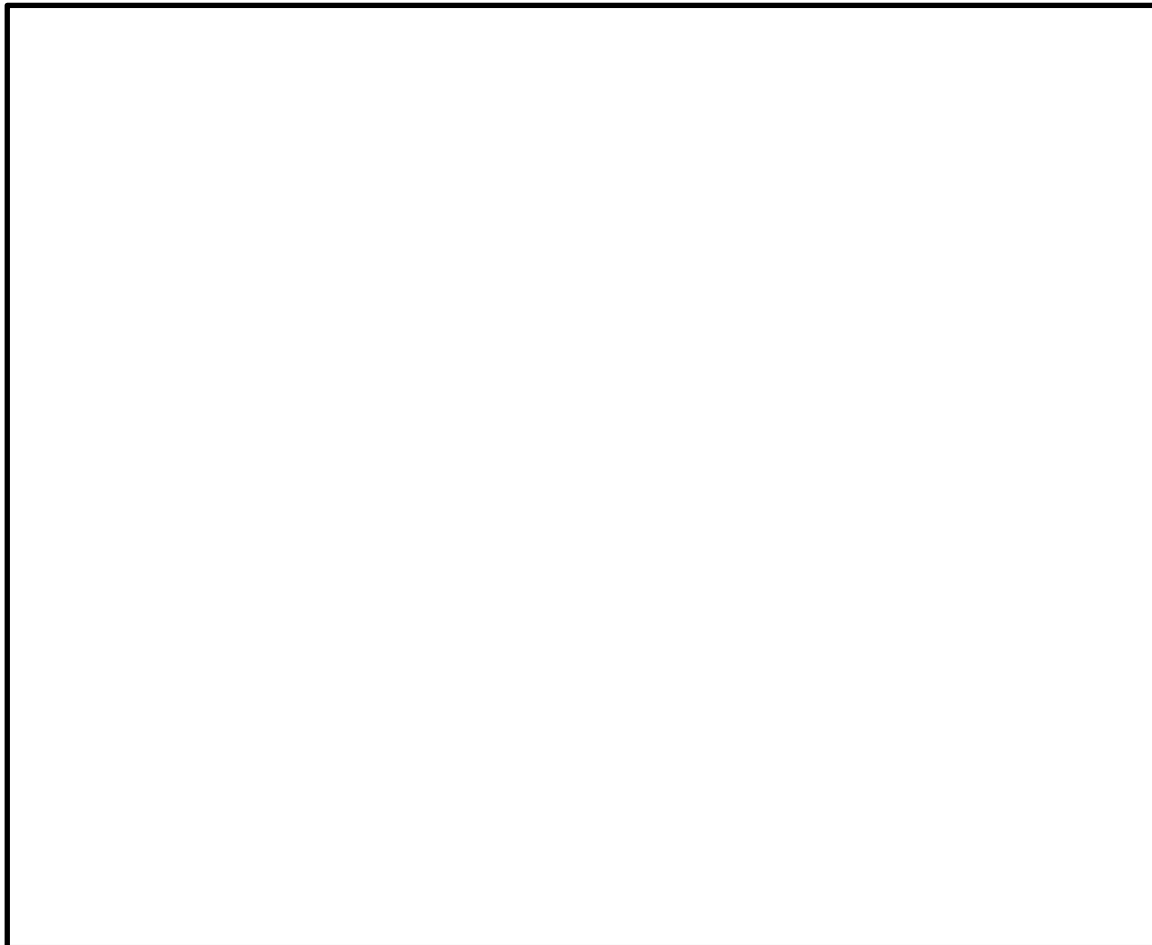

Additional comments:

**EXHIBIT A  
Single Service Drive  
Turn-A-Round Dimensions**

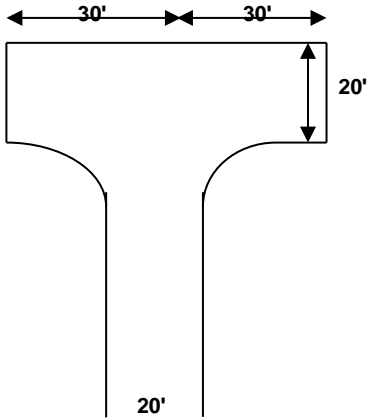

**60' Alternate Hammerhead**

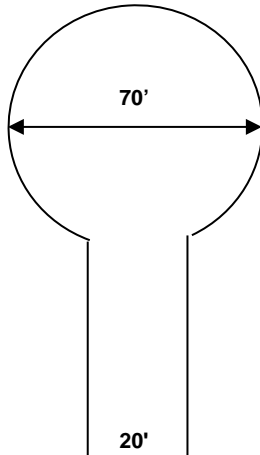

**70' Diameter Cul-de-Sac**

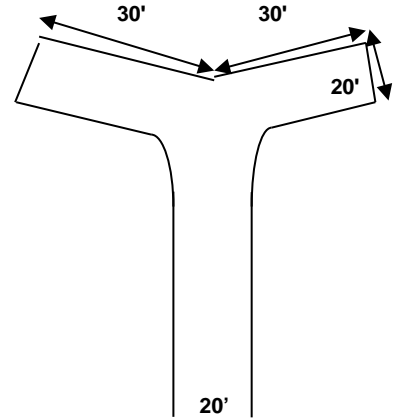

**Hammerhead Alternate #1**

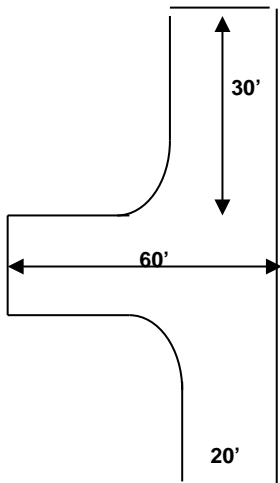

**Hammerhead Alternate #2**

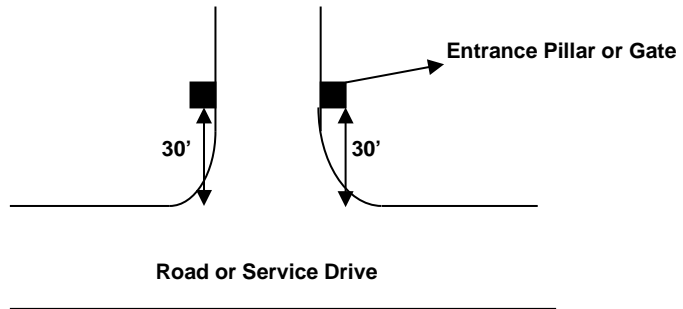

**Pillar / Entrance Setback**

**Agriculture/Accessory Building Turnout**

